

# 3 Port Solenoid Valve Direct Operated Poppet Type

New

CE

RoHS

Power consumption

**4 W**  
Standard type

(Existing product: 4.8 W)

**1.8 W**  
Energy-saving type

(Existing product: 2 W)

Vacuum applications

**-101.2**  
kPa

A single valve with various valve functions

(Universal porting type)

N.C. valve

N.O. valve

Divider valve

Selector valve

etc.

Low concentration ozone resistant

Rubber seal material: HNBR for main valve

Mounting dimensions are

**interchangeable** with existing product



Body ported type



Manifold type



Series **VT307**

**SMC**

CAT.EUS11-107A-UK





■ A variety of valve options



■ Application examples

<p>1 Blow-off valve</p>	<p>2 Pressure release valve</p>	<p>3 Selector valve</p>	<p>4 Valve for vacuum</p> <p>Vacuum pump (P)1 Vacuum pad</p> <p>Vacuum releasing air Atmospheric pressure or micro pressure</p>
<p>5 Divider valve</p>	<p>6 Single-acting cylinder drive</p>	<p>7 Double-acting cylinder drive</p>	<p>8 Double-acting cylinder drive (Exhaust centre)</p>

3 Port Solenoid Valve, Universal Porting Type Variations

Poppet type	Direct operated poppet type			Pilot poppet type
Series	 <b>New</b> <b>VT307</b>	 <b>VT317</b>	 <b>VT325</b>	 <b>VP300/500/700</b>
Cv (P↔A)	<b>0.19</b>	0.62	1.4	0.8 to 3.6

# 3 Port Solenoid Valve Direct Operated Poppet Type

## Series VT307



### Rubber Seal



### How to Order

V T 307 □ □ - 5 D □ 1 - 01 □ - F - Q

#### Body type

T	Body ported
O <small>Note 1) 2)</small>	For manifold

Note 1) Thread type is not applicable for manifold type.

Note 2) Bracket is not available for manifold type.

#### Valve option

—	Standard type
E	Continuous duty type
Y <small>Note 1)</small>	Energy-saving type
V <small>Note 2)</small>	Vacuum specification type
W <small>Note 1) 2)</small>	Energy-saving type, Vacuum specification type

Note 1) Valve options Y (Energy-saving type) and W (Energy-saving/vacuum specification type) are only applicable to the DC voltages.

Note 2) Combination of valve options V (Vacuum specification type) and W (Energy-saving/vacuum specification type) with K (High-pressure type) are not available.

#### Pressure specifications

—	Standard type (0.7 MPa)
K <small>Note)</small>	High-pressure type (1 MPa)

Note) Combination of valve options V (Vacuum specification type) and W (Energy-saving/vacuum specification type) with K (High-pressure type) are not available.

#### Rated voltage

1	100 VAC, 50/60 Hz
2	200 VAC, 50/60 Hz
3	110 VAC, 50/60 Hz
4	220 VAC, 50/60 Hz
5	24 VDC
6	12 VDC
7	240 VAC, 50/60 Hz
8	48 VAC, 50/60 Hz
B	24 VAC, 50/60 Hz
V	6VDC
W	32 VDC
Y	48 VDC
P	100 VDC

#### JIS Symbol

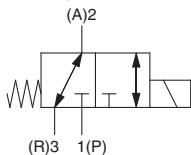

#### Manifold

Model	Applicable manifold type	Accessories
VO307□-Q	Common or individual exhaust	Function plate (DXT152-14-1A) <small>Note)</small> Mounting screw (NXT013-3)

Note) It is not applicable to the continuous duty type. Refer to the accessories on page 5.

#### Option

Description	Part no.
Bracket	DXT152-25-1A (With screw)

#### Bracket Note)

—	None
F	With bracket

Note) Bracket is not available for manifold type.

#### Thread type Note)

—	Rc
F	G
N	NPT
T	NPTF

Note) Thread type is not applicable for manifold type.

#### Port size

—	Without port (For manifold)
01	1/8 (6A)
02	1/4 (8A)

#### Light/Surge voltage suppressor

—	None
Z	With light/surge voltage suppressor

#### Electrical entry

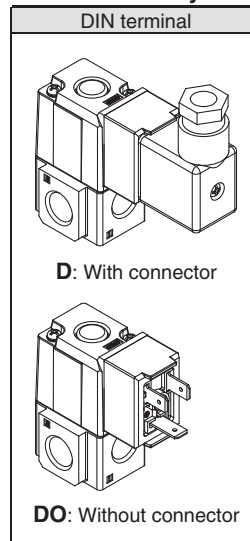

## Standard Specifications

### ⚠ Caution

Make sure that dust and/or other foreign materials do not enter the valve from the unused port (e.g. exhaust port).

<b>Type of actuation</b>		Direct operated type 2 position single solenoid
<b>Fluid</b>		Air
<b>Operating pressure range</b>		0 to 1 MPa (High-pressure type), 0 to 0.7 MPa (Standard type)
<b>Ambient and fluid temperature</b>		-10 to 50°C (No freezing)
<b>Response time</b> <small>Note 1)</small>		20 ms or less (at 0.5 MPa)
<b>Max. operating frequency</b>		10 Hz
<b>Lubrication</b>		Not required (Use turbine oil Class 1 ISO VG32, if lubricated.)
<b>Manual override</b>		Non-locking push type
<b>Mounting orientation</b>		Unrestricted
<b>Impact/Vibration resistance</b> <small>Note 2)</small>		150/50 m/s <sup>2</sup>
<b>Enclosure</b>		Dustproof
<b>Electrical entry</b>		DIN terminal
<b>Coil rated voltage [V]</b>	<b>AC (50/60 Hz)</b>	24, 48, 100, 110, 200, 220, 240
	<b>DC</b>	6, 12, 24, 32, 48, 100
<b>Allowable voltage fluctuation</b>		-15 to +10% of rated voltage
<b>Apparent power</b> <small>Note 3) Note 4)</small>	<b>AC</b>	12.7 VA (50 Hz), 10.7 VA (60 Hz)
	<b>Inrush Holding</b>	7.6 VA (50 Hz), 5.4 VA (60 Hz)
<b>Power consumption</b> <small>Note 3) Note 4)</small>		Without indicator light: 4 W, With indicator light: 4.2 W
<b>Light/Surge voltage suppressor</b>	<b>AC</b>	Varistor, LED
	<b>DC</b>	Diode, LED

Note 1) Based on dynamic performance test, JIS B 8374-1981. (Coil temperature: 20°C, at rated voltage, without surge voltage suppressor)

Note 2) Impact resistance: No malfunction occurred when it is tested with a drop tester in the axial direction and at the right angles to the main valve and armature in both energized and de-energized states every once for each condition. (Values at the initial period)

Vibration resistance: No malfunction occurred in a one-sweep test between 45 and 1000 Hz. Test was performed at both energized and de-energized states in the axial direction and at the right angles to the main valve and armature. (Values at the initial period)

Note 3) At rated voltage

Note 4) The value is different for continuous duty type (VT307E), and energy-saving type (VT307Y/W). Refer to "Valve Options" shown below.

## Flow-rate Characteristics

Valve model	Port size	Flow-rate characteristics															
		1 → 2 (P → A)				2 → 3 (A → R)				3 → 2 (R → A)				2 → 1 (A → P)			
		C [dm <sup>3</sup> /(s·bar)]	b	Cv	Q [L/min] (ANR) <sup>Note 2)</sup>	C [dm <sup>3</sup> /(s·bar)]	b	Cv	Q [L/min] (ANR) <sup>Note 2)</sup>	C [dm <sup>3</sup> /(s·bar)]	b	Cv	Q [L/min] (ANR) <sup>Note 2)</sup>	C [dm <sup>3</sup> /(s·bar)]	b	Cv	Q [L/min] (ANR) <sup>Note 2)</sup>
<b>VT307</b> VT307V (Vacuum spec. type) VT307E (Continuous duty type) VT307Y (Energy-saving type) VT307W (Energy-saving, Vacuum spec. type)	1/8	0.71	0.35	0.18	187	0.68	0.27	0.17	170	0.65	0.36	0.17	172	0.63	0.35	0.17	166
<b>VT307</b> VT307V (Vacuum spec. type) VT307E (Continuous duty type) VT307Y (Energy-saving type) VT307W (Energy-saving, Vacuum spec. type)	1/4	0.71	0.31	0.19	182	0.71	0.25	0.17	175	0.68	0.33	0.17	176	0.71	0.26	0.18	176
		0.49	0.20	0.12	117	0.44	0.34	0.11	115	0.48	0.17	0.12	113	0.46	0.28	0.11	116

Note 1) Values for a single valve unit. It is not applicable to the manifold. Refer to the manifold specifications on page 5.

Note 2) These valves have been calculated according to ISO6358 and indicate the flow rate under standard conditions with an inlet pressure of 0.6 MPa (relative pressure) and a pressure drop of 0.1 MPa.

## Valve Options

### Continuous duty type: VT307E

Exclusive use of VT307E is recommended for continuous duty with long time loading.

### ⚠ Caution

1. This model is for continuous duty, not for high cycle rates. But even in low cycle rates, if energizing the valve more than once a day, please consult with SMC.
2. Energizing solenoid should be done at least once in 30 days.

Specifications different from standard are as follows.

Apparent power/AC	Inrush	7.9 VA (50 Hz), 6.2 VA (60 Hz)
	Holding	5.8 VA (50 Hz), 3.5 VA (60 Hz)
Power consumption/DC		1.8 W, With indicator light: 2 W
Response time <small>Note)</small>		30 ms or less (at 0.5 MPa)

Note) Refer to Note 1) of the standard specifications.

### Energy-saving type: VT307Y (VT307W)

If low power consumption is required for electronic control, "VT307Y(W)" (1.8 W) is recommended.

Specifications different from standard are as follows.

Power consumption/DC	1.8 W, With indicator light: 2 W
Response time <small>Note)</small>	25 ms or less (at 0.5 MPa)

Note) Refer to Note 1) of the standard specifications.

### Vacuum spec. type: VT307V (VT307W)

This vacuum model has less air leakage than the standard model under low pressure. It is recommended for vacuum application.

### ⚠ Caution

Since this valve has slight air leakage, it can not be used for vacuum holding (including positive pressure holding) in the pressure container.

Specifications different from standard are as follows.

Operating pressure range	-101.2 kPa to 0.1 MPa
--------------------------	-----------------------

## Construction

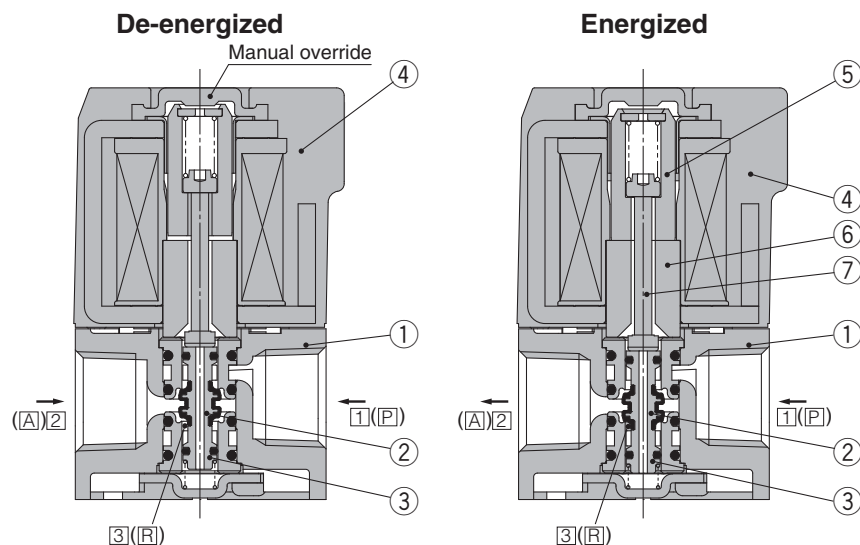

### Operation principle

#### <De-energized>

Poppet valve ② is pushed upward by the return spring ③, port ① is closed. Then, port ② and port ③ are connected.

Air flow direction:

Port ① ↔ Block, ② ↔ ③

#### <Energized>

When energizing the molded coil ④, the armature ⑤ is magnetically attracted to the core ⑥, and through the push rod ⑦, it pushes down the poppet valve ② and port ③ is closed. Then, port ① and port ② are connected. At this time, there will be gaps between the armature ⑤ and the core ⑥, but the armature ⑤ will be magnetically firmly attracted to the core ⑥.

Air flow direction:

Port ① ↔ Port ②, Port ③ ↔ Block

### Component Parts

No.	Description	Material	Note
1	Body	Aluminium die-casted	Colour: White
2	Poppet valve	Aluminium, HNBR	
3	Return spring	Stainless steel	
4	Molded coil	Resin	

## How to Use DIN Terminal

### 1. Disassembly

- After loosening the screw ①, then if the housing ② is pulled in the direction of the screw ①, the connector will be removed from the body of equipment (solenoid, etc.).
- Pull the screw ① out of the housing ②.
- On the bottom part of the terminal block ③, there's a cut-off part ⑨. If a small flat head screwdriver is inserted between the opening in the bottom, terminal block ③ will be removed from the housing ②.
- Remove the cable gland ④, plain washer ⑤ and rubber seal ⑥.

### 2. Wiring

- Pass the cable ⑦ through the cable gland ④, plain washer ⑤ and rubber seal ⑥ in this order, and then insert them into the housing ②.
  - Loosen the screw ① attached to the terminal block ③. Then, pass the lead wire ⑩ through the terminal block ③ and tighten the screw ① again.
- Note 1) Tighten within the tightening torque of 0.5 N·m ±15%.
- Note 2) Cable ⑦ outside diameter: ø6 to ø8 mm
- Note 3) Crimped terminal like round-shape or Y-shape cannot be used.

### 3. Assembly

- Pass the cable ⑦ through the cable gland ④, plain washer ⑤ and rubber seal ⑥ in this order and connect to the terminal block ③. Then, mount the terminal block ③ on the housing ②. (Push it down until you hear the click sound.)
  - Put the rubber seal ⑥ and plain washer ⑤ in this order into the cable entry of the housing ②, and then tighten the cable gland ④ securely.
  - Insert the gasket ⑧ between the bottom part of terminal block ③ and the plug attached to the equipment. Then, screw in ① from the top of the housing ② to tighten it.
- Note 1) Tighten within the tightening torque of 0.5 N·m ±20%.
- Note 2) Connector orientation can be changed 180° depending on how the housing ② and the terminal block ③ are assembled.

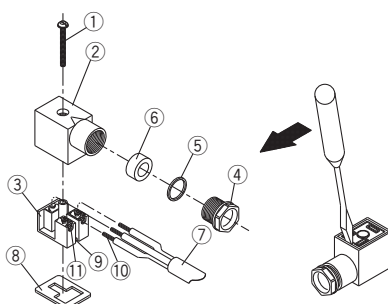

### Connector for DIN Terminal

Description	Part no.
DIN connector	GM209NJ-B17

## ⚠ Caution

### Light/Surge Voltage Suppressor

#### AC

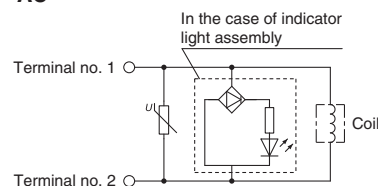

#### DC

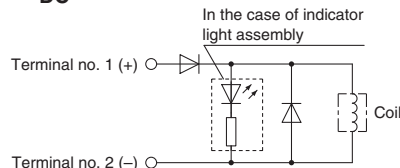

## Electrical Connection

DIN terminal is connected inside as in the figure below. Connect to the corresponding power supply.

### DIN terminal block

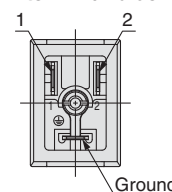

Terminal no.	1	2
DIN terminal	+	-

· Applicable cable O.D.  
ø6 to ø8

## Lead Wire Colour

Voltage	Colour
100 VAC	Blue
200 VAC	Red
DC	Red (+), Black (-)
Others	Grey

# Series VT307

## Dimensions

DIN terminal: VT307-□D1

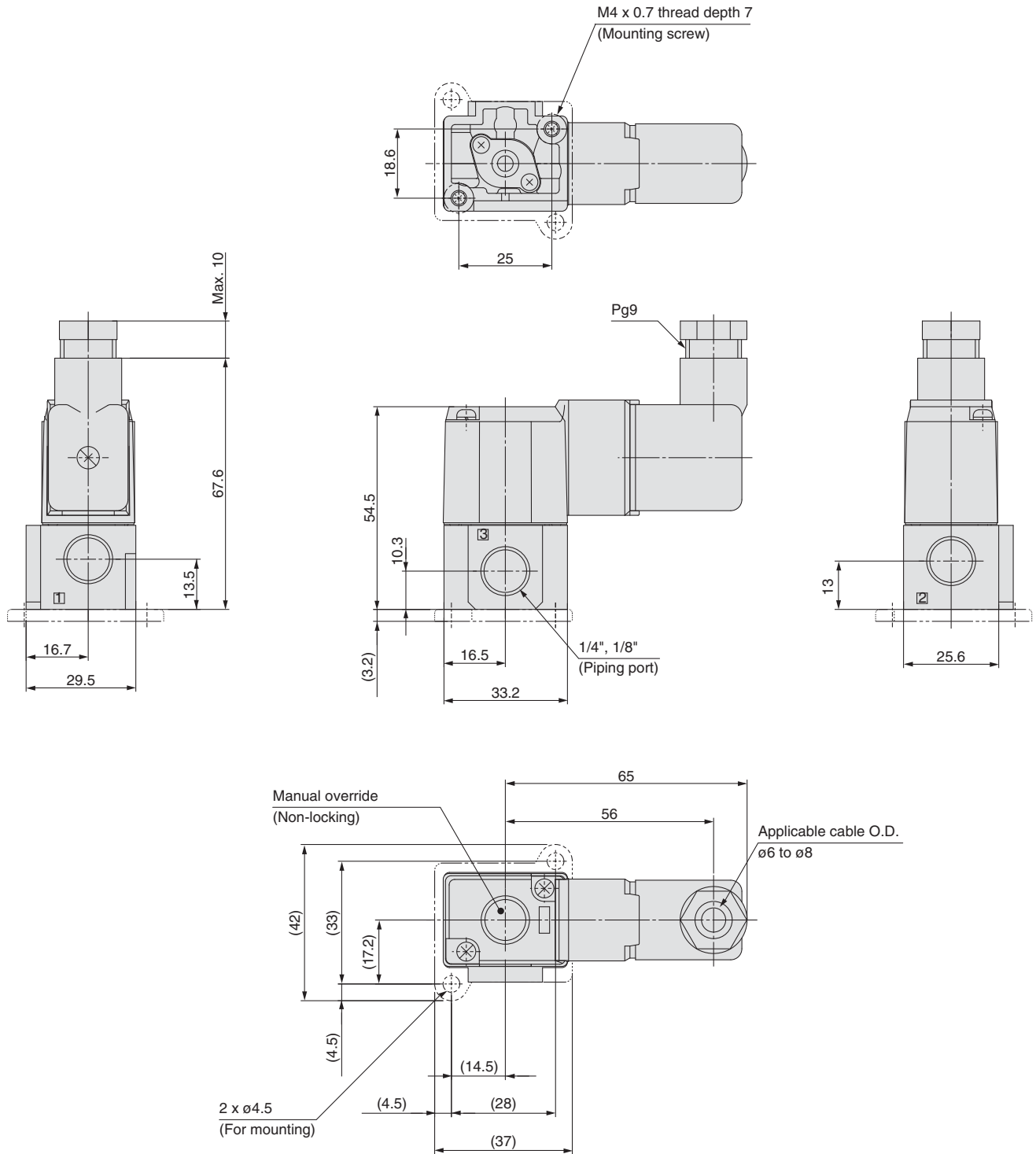

# Series VT307

# Manifold Specifications

VT307 manifold is available both as a common exhaust and individual exhaust model.

Manifold valve can be easily converted from N.C. (Normally Closed) to N.O. (Normally Open) merely by turning over the function plate.



Common exhaust  
VV307-01-052-□-F



Individual exhaust  
VV307-01-053-□-F

## How to Order Manifold Base

**VV307-01-052-01-□-F**

- Dummy symbol**
- VT307 manifold**
- Valve stations**

02	2 stations
⋮	⋮
20	20 stations

Max. 20 stations
- Exhaust port type**

2	Common exhaust
3	Individual exhaust
- A port size (Base mounted)**

01	1/8 common exhaust/individual exhaust
02	1/4 individual exhaust
- Thread type**

—	Rc
F	G
N	NPT
T	NPTF
- Mounting bracket**

\* Specify model number of the manifold base, applicable valves and blanking plates when ordering.  
Refer to page 1 for the model number of the valves.  
Ordering example: VV307-01-052-01-F... 1 pc.  
(5 station manifolds base)  
VO307-1D1.....4 pcs.  
DXT060-51-13A.....1 pc.  
(Blanking plate)

## Manifold Specifications

<b>Manifold type</b>	B mount			
<b>Max. number of stations</b>	20 stations <sup>Note)</sup>			
<b>Applicable solenoid valve</b>	VO307□-□□□□-Q			
Exhaust port		Port location (Direction)/Port size		
Symbol	Type	P	A	R
2	Common	Base (Side) 1/8	Base (Side) 1/8	Base (Side) 1/8
3	Individual	Base (Side) 1/4	Base (Side) 1/8, 1/4	Base (Top) 1/8

Note) For 6 stations or more, supply air both sides of P port. The common exhaust type should exhaust from both of the R port.

## Option

Description	Part no.
Blanking plate (With gasket, screw) <sup>Note)</sup>	DXT060-51-13 <sup>A</sup> <sub>B</sub>

## Accessories for Applicable Solenoid Valve

Description	Part no.	Qty.
Function plate (With gasket) <sup>Note)</sup>	DXT152-14-1 <sup>A</sup> <sub>B</sub>	1 pc.
Mounting screws	NXT013-3	2 pcs.

Note) DXT060-51-13B, DXT152-14-1B are for the continuous duty type.

## Flow-rate Characteristics

Valve model	Flow-rate characteristics															
	1 → 2 (P → A)			2 → 3 (A → R)			3 → 2 (R → A)			2 → 1 (A → P)						
	C [dm <sup>3</sup> /(s·bar)]	b	Cv	Q [L/min] (ANR) <sup>Note)</sup>	C [dm <sup>3</sup> /(s·bar)]	b	Cv	Q [L/min] (ANR) <sup>Note)</sup>	C [dm <sup>3</sup> /(s·bar)]	b	Cv	Q [L/min] (ANR) <sup>Note)</sup>	C [dm <sup>3</sup> /(s·bar)]	b	Cv	Q [L/min] (ANR) <sup>Note)</sup>
VO307	0.34	0.28	0.089	85	0.089	0.22	0.082	82	0.36	0.28	0.091	90	0.34	0.18	0.080	81
VO307V (Vacuum spec. type)																
VO307E (Continuous duty type)																
VO307Y (Energy-saving type)	0.30	0.18	0.070	71	0.070	0.15	0.072	70	0.32	0.20	0.075	77	0.30	0.15	0.069	70
VO307W (Energy-saving, Vacuum spec. type)																

Note) These valves have been calculated according to ISO6358 and indicate the flow rate under standard conditions with an inlet pressure of 0.6 MPa (relative pressure) and a pressure drop of 0.1 MPa.

# Series VT307

## Dimensions: Common Exhaust

VV307-01-□2-01-F

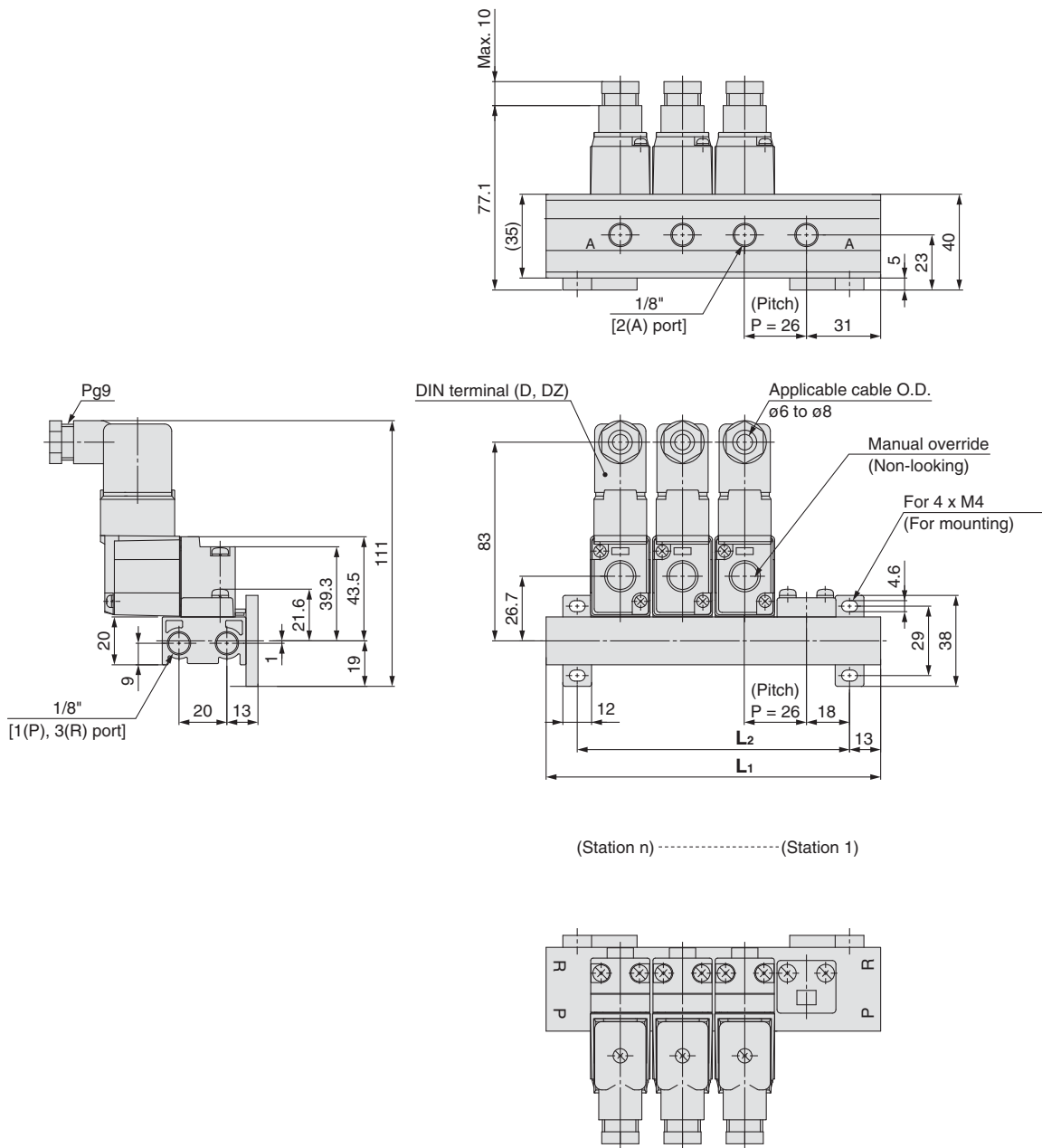

### L Dimension

n: Stations

L \ n	2	3	4	5	6	7	8	9	10	Formula
L <sub>1</sub>	88	114	140	166	192	218	244	270	296	L <sub>1</sub> = 26 x n + 36
L <sub>2</sub>	62	88	114	140	166	192	218	244	270	L <sub>2</sub> = 26 x n + 10



# 3 Port Solenoid Valve Direct Operated Poppet Type *Series VT307*

## Dimensions: Individual Exhaust

VV307-01-□3-□-F

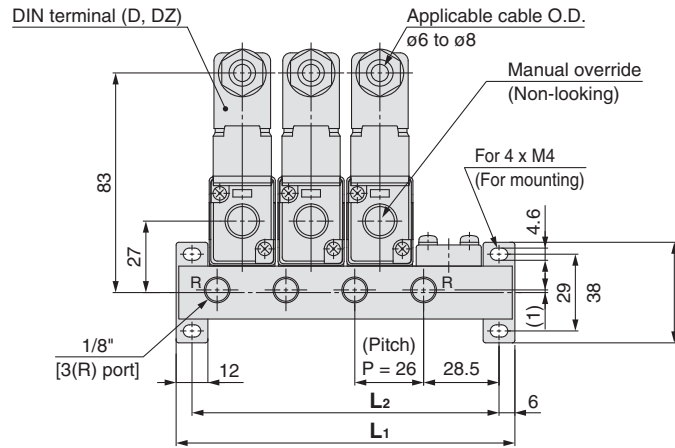
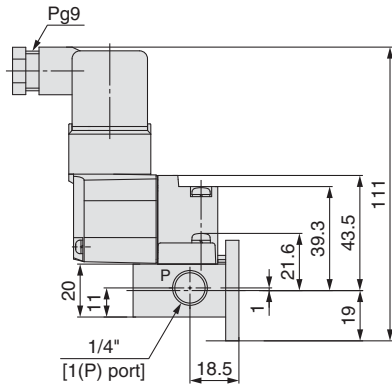
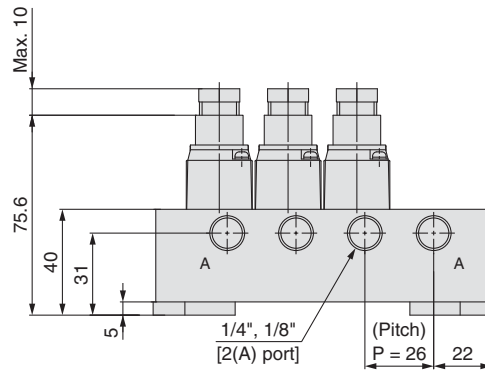

(Station n) ..... (Station 1)

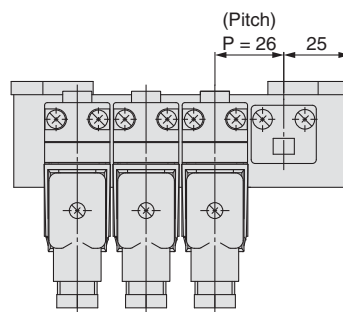

### L Dimension

n: Stations

L \ n	2	3	4	5	6	7	8	9	10	Formula
L <sub>1</sub>	76	102	128	154	180	206	232	258	284	L <sub>1</sub> = 26 x n + 24
L <sub>2</sub>	64	90	116	142	168	194	220	246	272	L <sub>2</sub> = 26 x n + 12



# Series VT307

## Specific Product Precautions

Be sure to read before handling. Refer to back cover for Safety Instructions and “Handling Precautions for SMC Products” (M-E03-3) for 3/4/5 Port Solenoid Valve Precautions.

### Mounting

#### Warning

When mounting a valve on the manifold base, N.C. and N.O. can be reversed by the function plate orientation. Also, since the cylinder operates in reverse, confirm if the function plate is correctly mounted or not.

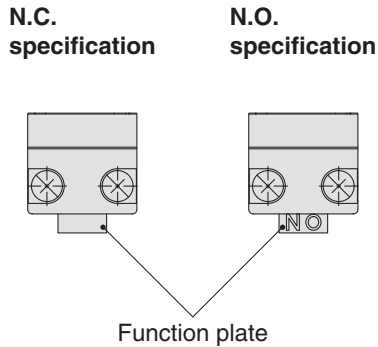

#### Caution

1. Each valve is fixed to the manifold base with two M4 mounting screws. Tighten the screws firmly when re-mounting.
2. For mounting, tighten M4 or equivalent screws evenly into the mounting holes of the manifold base.  
Tightening torque of the mounting screw (M4): 1.4 N·m

### Changing from N.C. to N.O.

#### Caution

This product is delivered as N.C. valve. If N.O. valve is required, remove mounting screws of the required valve and turn over the function plate. (Make sure that there are gaskets on both sides of the plate.) Then, tighten the mounting screws to fix the valve to the manifold base.

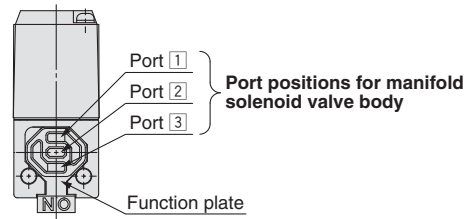

Figure: For N.C.

Specifications	Function plate
N.C.	No mark
N.O.	NO

### Piping



#### Caution

1. For the common exhaust type, pressurisation or evacuation of the 3(R) port can cause a malfunction.



## Safety Instructions

These safety instructions are intended to prevent hazardous situations and/or equipment damage. These instructions indicate the level of potential hazard with the labels of “**Caution**,” “**Warning**” or “**Danger**.” They are all important notes for safety and must be followed in addition to International Standards (ISO/IEC)\*1), and other safety regulations.

-  **Caution:** **Caution** indicates a hazard with a low level of risk which, if not avoided, could result in minor or moderate injury.
-  **Warning:** **Warning** indicates a hazard with a medium level of risk which, if not avoided, could result in death or serious injury.
-  **Danger:** **Danger** indicates a hazard with a high level of risk which, if not avoided, will result in death or serious injury.

- \*1) ISO 4414: Pneumatic fluid power – General rules relating to systems.  
 ISO 4413: Hydraulic fluid power – General rules relating to systems.  
 IEC 60204-1: Safety of machinery – Electrical equipment of machines.  
 (Part 1: General requirements)  
 ISO 10218-1: Manipulating industrial robots - Safety.  
 etc.

### Warning

- 1. The compatibility of the product is the responsibility of the person who designs the equipment or decides its specifications.**  
 Since the product specified here is used under various operating conditions, its compatibility with specific equipment must be decided by the person who designs the equipment or decides its specifications based on necessary analysis and test results. The expected performance and safety assurance of the equipment will be the responsibility of the person who has determined its compatibility with the product. This person should also continuously review all specifications of the product referring to its latest catalogue information, with a view to giving due consideration to any possibility of equipment failure when configuring the equipment.
- 2. Only personnel with appropriate training should operate machinery and equipment.**  
 The product specified here may become unsafe if handled incorrectly. The assembly, operation and maintenance of machines or equipment including our products must be performed by an operator who is appropriately trained and experienced.
- 3. Do not service or attempt to remove product and machinery/equipment until safety is confirmed.**
  1. The inspection and maintenance of machinery/equipment should only be performed after measures to prevent falling or runaway of the driven objects have been confirmed.
  2. When the product is to be removed, confirm that the safety measures as mentioned above are implemented and the power from any appropriate source is cut, and read and understand the specific product precautions of all relevant products carefully.
  3. Before machinery/equipment is restarted, take measures to prevent unexpected operation and malfunction.
- 4. Contact SMC beforehand and take special consideration of safety measures if the product is to be used in any of the following conditions.**
  1. Conditions and environments outside of the given specifications, or use outdoors or in a place exposed to direct sunlight.
  2. Installation on equipment in conjunction with atomic energy, railways, air navigation, space, shipping, vehicles, military, medical treatment, combustion and recreation, or equipment in contact with food and beverages, emergency stop circuits, clutch and brake circuits in press applications, safety equipment or other applications unsuitable for the standard specifications described in the product catalogue.
  3. An application which could have negative effects on people, property, or animals requiring special safety analysis.
  4. Use in an interlock circuit, which requires the provision of double interlock for possible failure by using a mechanical protective function, and periodical checks to confirm proper operation.

### Caution

- 1. The product is provided for use in manufacturing industries.**  
 The product herein described is basically provided for peaceful use in manufacturing industries.  
 If considering using the product in other industries, consult SMC beforehand and exchange specifications or a contract if necessary.  
 If anything is unclear, contact your nearest sales branch.

## Limited warranty and Disclaimer/ Compliance Requirements

The product used is subject to the following “Limited warranty and Disclaimer” and “Compliance Requirements”.

Read and accept them before using the product.

### Limited warranty and Disclaimer

1. The warranty period of the product is 1 year in service or 1.5 years after the product is delivered, whichever is first.\*2)  
 Also, the product may have specified durability, running distance or replacement parts. Please consult your nearest sales branch.
2. For any failure or damage reported within the warranty period which is clearly our responsibility, a replacement product or necessary parts will be provided.  
 This limited warranty applies only to our product independently, and not to any other damage incurred due to the failure of the product.
3. Prior to using SMC products, please read and understand the warranty terms and disclaimers noted in the specified catalogue for the particular products.

\*2) Vacuum pads are excluded from this 1 year warranty.

A vacuum pad is a consumable part, so it is warranted for a year after it is delivered. Also, even within the warranty period, the wear of a product due to the use of the vacuum pad or failure due to the deterioration of rubber material are not covered by the limited warranty.

### Compliance Requirements

1. The use of SMC products with production equipment for the manufacture of weapons of mass destruction (WMD) or any other weapon is strictly prohibited.
2. The exports of SMC products or technology from one country to another are governed by the relevant security laws and regulations of the countries involved in the transaction. Prior to the shipment of a SMC product to another country, assure that all local rules governing that export are known and followed.

## Safety Instructions

Be sure to read “Handling Precautions for SMC Products” (M-E03-3) before using.

### SMC Corporation (Europe)

Austria	☎ +43 (0)2262622800	www.smc.at	office@smc.at
Belgium	☎ +32 (0)33551464	www.smc-pneumatics.be	info@smc-pneumatics.be
Bulgaria	☎ +359 (0)2807670	www.smc.bg	office@smc.bg
Croatia	☎ +385 (0)13707288	www.smc.hr	office@smc.hr
Czech Republic	☎ +420 541424611	www.smc.cz	office@smc.cz
Denmark	☎ +45 70252900	www.smc.dk.com	smc@smcdk.com
Estonia	☎ +372 6510370	www.smc-pneumatics.ee	smc@smc-pneumatics.ee
Finland	☎ +358 207513513	www.smc.fi	smcffi@smc.fi
France	☎ +33 (0)164761000	www.smc-france.fr	promotion@smc-france.fr
Germany	☎ +49 (0)61034020	www.smc.de	info@smc.de
Greece	☎ +30 210 2717265	www.smc-hellas.gr	sales@smc-hellas.gr
Hungary	☎ +36 23511390	www.smc.hu	office@smc.hu
Ireland	☎ +353 (0)14039000	www.smc-pneumatics.ie	sales@smc-pneumatics.ie
Italy	☎ +39 0292711	www.smc-italia.it	mailbox@smc-italia.it
Latvia	☎ +371 67817700	www.smc.lv	info@smc.lv

Lithuania	☎ +370 5 2308118	www.smclt.lt	info@smclt.lt
Netherlands	☎ +31 (0)205318888	www.smc-pneumatics.nl	info@smc-pneumatics.nl
Norway	☎ +47 67129020	www.smc-norge.no	post@smc-norge.no
Poland	☎ +48 (0)222119616	www.smc.pl	office@smc.pl
Portugal	☎ +351 226166570	www.smc.eu	postpt@smc.smces.es
Romania	☎ +40 213205111	www.smcromania.ro	smcromania@smcromania.ro
Russia	☎ +7 8127185445	www.smc-pneumatik.ru	info@smc-pneumatik.ru
Slovakia	☎ +421 (0)413213212	www.smc.sk	office@smc.sk
Slovenia	☎ +386 (0)73885412	www.smc.si	office@smc.si
Spain	☎ +34 902184100	www.smc.eu	post@smc.smces.es
Sweden	☎ +46 (0)86031200	www.smc.nu	post@smc.nu
Switzerland	☎ +41 (0)523963131	www.smc.ch	info@smc.ch
Turkey	☎ +90 212 489 0 440	www.smc-pneumatik.com.tr	info@smc-pneumatik.com.tr
UK	☎ +44 (0)845 121 5122	www.smc-pneumatics.co.uk	sales@smc-pneumatics.co.uk